

Original Design Flatbed
One, Two, and Three Needle
Chainstitch

56300 56500 56900



56900R9

OPERATIONS & SUBCLASSES





 *Union Special*
FINEST QUALITY

- **Seaming operations on light to medium weight fabrics—56300 styles**
Single needle general seaming for a variety of sewn products.
- **Lapseaming operations on medium to heavy weight fabrics—56500 styles**
Two needle full felled seaming for denim products.
- **Lapseaming operations on medium to heavy weight fabrics—56900 styles**
Three needle full felled seaming for denim products.

SPECIFICATIONS

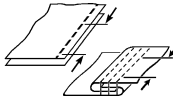

Model No.	56300F/R	56300G	56300AV	56300V	56500R	56900P/R
Needle	128GBS080/032~150/060		130GHS080/032~140/054		147GKS090/036~140/054	
	standard 090/036	standard 080/032	standard 100/040	standard 090/036	standard 125/049	
Material Weight	light to medium	medium	medium	light to medium	medium to heavy	
Stitch Length Adjustment	by adjusting screw					
Needle Bar Stroke	30.5mm				33.4mm	
Lubrication	automatic					
Lubricating Oil	Union Special Spec 175 (ISO grade 22)					
Stitch Type	401				401	401
Seam Type	SSa-1				LSc-2	LSc-3

						
56300F	1	2	—	2.1~3.6 (3.2 standard)	6.4mm	6500 RPM
56300G	1	2	—	1.8~2.5 (2.1 standard)	6.4mm	6500 RPM
56300R	1	2	—	2.1~3.6 (3.2 standard)	6.4mm	6000 RPM
56300AV	1	2	—	2.5~4.2 (3.2 standard)	4.8mm	6500 RPM
56300V	1	2	—	1.6~2.8 (2.1 standard)	4.8mm	6500 RPM
56500R16	2	4	6.4mm	1.8~3.6 (3.2 standard)	6.4mm	6000 RPM
56500R18	2	4	7.2mm	1.8~3.6 (3.2 standard)	6.4mm	6000 RPM
56900P8	3	6	3.2mm	1.8~3.6 (3.2 standard)	8mm	6000 RPM
56900P9	3	6	3.6mm	1.8~3.6 (3.2 standard)	8mm	6000 RPM
56900R8	3	6	3.2mm	1.8~3.6 (3.2 standard)	8mm	6000 RPM
56900R9	3	6	3.6mm	1.8~3.6 (3.2 standard)	8mm	6000 RPM

Original Design Flatbed Single Needle Chainstitch 56300 Styles

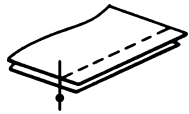

56300F

One needle, two thread, medium throw, plain feed machine. With feeding foot and needle thread ratio control. For seaming men's trousers, coats or other garments made from light to medium weight material. (Similar to FS311S11-1M.)

56300G

One needle, two thread, medium throw, plain feed machine. With needle thread ratio control. For seaming men's trousers, coats or other garments made from light to medium weight material. (Similar to FS311S01-1M.)

56300R

One needle, two thread, medium throw plain feed machine. With feeding foot that has a left yielding section, and needle thread ratio control. For crossing side, sleeve, or pocket seams on men's trousers, coats or other garments made from light to medium weight material. (Similar to FS311S12-1M.)

56300AV

One needle, two thread, medium throw, plain feed machine for cotton flannel glove closing. With narrow presser foot and four motion retainer mechanism, to prevent skipped stitches at sharp turns of glove fingers.

56300AV

One needle, two thread, medium throw, plain feed machine. With backtacking mechanism and four motion retainer mechanism. For seaming or hemming dresses, shirts, towels, sheets, curtains and similar light to medium weight wovens, where backtacking is required.

Original Design Flatbed Two and Three Needle Chainstitch 56500 and 56900 Styles

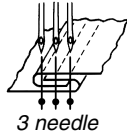
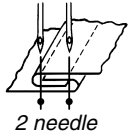

56500R16/18

Two needle, four thread, high throw, plain feed machine. With tractor presser foot and 1/8" capacity double lap seam folder. Parts are designed for chaining between pieces.

For attaching risers to jeans, attaching bibs to overalls, and piecing sleeves on jackets made from medium to heavy weight denim.

(Similar to FS311L51-2H64/72.)

56900P8/9

Three needle, six thread, high throw, plain feed machine. With tractor presser foot and 1/8" capacity double lap seam folder. Flat parts are designed for chaining between pieces.

For attaching risers to jeans, attaching bibs to overalls, and piecing sleeves on jackets made from medium to heavy weight denim.

(Similar to FS311L52-3H32/36.)

56900R8/9

Three needle, six thread, high throw, plain feed machine. With tractor presser foot and 1/8" capacity double lap seam folder. Stepped parts have 1.75mm step to the right of the needles, and are designed for chaining between pieces. For seat seaming and similar operations on jeans, overalls, and jackets made from medium to heavy weight denim.

(Similar to FS311L53-3H32/36.)



SEWING PARTS

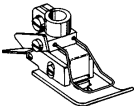
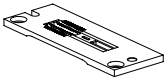
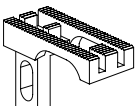

Single Needle Chainstitch Spare Parts Matrix

STYLE			
	PRESSER FOOT ASSEMBLY	THROAT PLATE	FEED DOG
56300F	56320F	C51324W	51305W
56300G	G51320	G51324	51305A
56300R	56320H	C51324W	51305W
56300AV	43220D	C51224W	51205W
56300V	51320N	C56324A	56305A

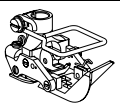
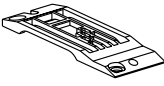
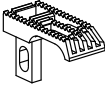
2 & 3 Needle Chainstitch Spare Parts Matrix

STYLE				
	PRESSER FOOT ASSEMBLY	THROAT PLATE	FEED DOG	NEEDLE HEAD
56500R16	C50020F16	C50024R16	C50005N	51418-16
56500R18	C50020E18	C50024U18	C50005N	7018E5
56900P8	50320M8	50324N8	56905A9	35818N8
56900P9	56920A9	C56924A9	56905A9	C50018B9
56900R8	50320N8	50324P8	56905R9	35818N8
56900R9	56920R9	C56924R9	56905R9	C50018B9

DEVICES & ATTACHMENTS



INSTALLATIONS



Use this chart to choose the correct table top for 56300/56500/56900 machines. Table top dimensions are 51cm x 122cm. Underboard of 21371RY48 can be adjusted for use as a semi-submerged or fully submerged installation.

Model No.	Table Board Part Number	Table Board Description
56300/56500/56900 all styles	21371RY48	Semi-Submerged
	21371NT48	Non-Submerged

ADDITIONAL INFORMATION



In addition to the 1/8" capacity folder that comes standard on multi-needle 56000 styles, two other sizes of full felled lapseam folders are available.

folder number \ machine style	56500R16	56500R18	56900P8	56900P9	56900R8	56900R9
23420S8-3/32	optional		optional		optional	
23420S9-3/32		optional		optional		optional
23420S8-1/8	standard		standard		standard	
23420S9-1/8		standard		standard		standard
23420S8-5/32	optional		optional		optional	
23420S9-5/32		optional		optional		optional

HOW TO ORDER



**SINGLE NEEDLE
 HIGH SPEED
 GLOVE CLOSING MACHINE**



Style 56300 AV is a single needle, high speed, glove closing machine equipped with a four-motion retainer. The retainer serves to keep the thread triangle open to effectively prevent skipping when making the short radius turns around the fingers. This machine is designed for closing cotton flannel gloves or other gloves of similar material. The 56300 AV has the capability of operating at 6500 RPM (depending on operation) to increase production.

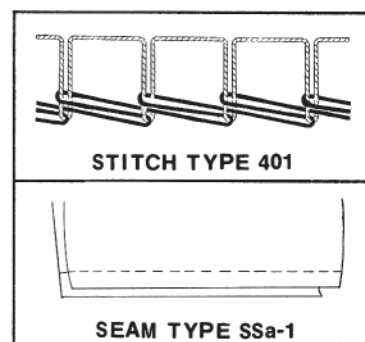

DESCRIPTION			SPECIFICATIONS			
MACHINE	FEATURES	APPLICATION	SEAM STITCH TYPE	FABRIC WEIGHT & TYPES	STITCHES PER INCH	MAXIMUM* SPEED
56300AV	Single needle bobbinless machine with four motion retainer to prevent skipping at sharp turns.	Closing cotton flannel gloves	401-SSa-1	Cotton flannel gloves	6 to 10 8 standard	6500 RPM

*DEPENDENT ON OPERATION

WORLDWIDE SALES AND SERVICE

Union Special Machine Company
 One Union Special Plaza
 Huntley, Illinois 60142

www.unionspecial.com
www.the-needles-eye.com
www.juki.com

Single-needle, plain-feed
"Double Lock" stitch machines
with "FEEDING FOOT"
auxiliary feeding system
for seaming trousers and coats

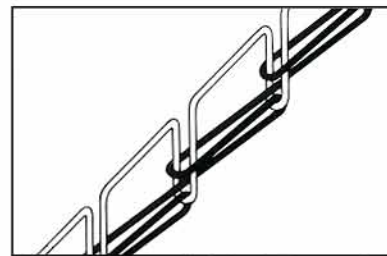

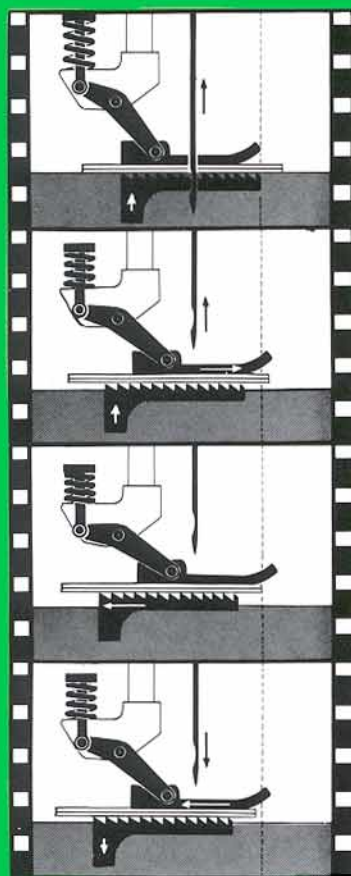

"Double Lock" Stitch Type 401



These advanced series Class 56300 machines are designed with a unique presser foot which assists in feeding the top ply of fabric without the need for additional drive mechanisms. The upper feed provides the advantage of even feeding without losing production speed. The "FEEDING FOOT" allows the operator to match patterns and produce virtually pucker-free seams even on hard-to-handle fabrics.

Single-needle, plain-feed
“Double Lock” stitch machines
with “FEEDING FOOT”
auxiliary feeding system
for seaming trousers and coats

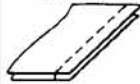

DESCRIPTION			SPECIFICATIONS			
MACHINE	FEATURES	APPLICATION	SEAM AND STITCH TYPE	FABRIC WEIGHT AND TYPE	STITCHES PER INCH	MAXIMUM SPEED*
56300 F “Feeding Foot” Seamer	Single-needle, plain-feed machine. Unique design of presser foot assists in feeding top ply of fabric without the burden of any other drive mechanism.	For seaming men’s trousers and coats made from hard-to-handle fabrics. “Feeding Foot” aids matching plies and patterns while producing a pucker-free seam.	401 SSa-1 	Medium weight knit and woven materials.	7-11	6500 RPM
56300 R “Feeding Foot” Seamer	Presser foot assists in feeding top ply of fabric. Similar to Style 56300 F except presser foot has left yielding section for crossing front pocket seams.	For seaming men’s trousers when it is necessary to cross heavy front pocket seams.	401 SSa-1 	Medium weight knit and woven materials.	7-11	6500 RPM

*Depending on operation.

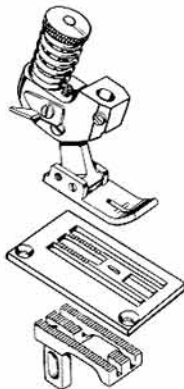

Sewing parts for
Style 56300 F

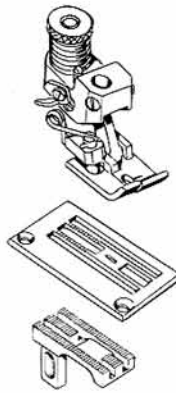

Sewing parts for
Style 56300 R



The “FEEDING FOOT” presser foot is designed to sew durable press and other hard-to-handle materials, match plies and patterns evenly, and to minimize puckering.

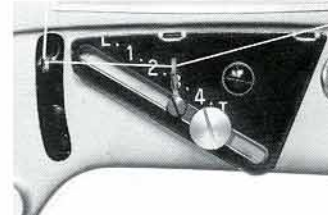

The thumbscrew adjustable needle thread frame eyelet assembly is capable of reducing seam pucker using a loose stitch as required with one fast, simple adjustment. This new indexed thread ratio control is calibrated clearly so that, with the machine set for one type of material, the operator, by simply moving the eyelet to a new position, can obtain the stitch best suited to other types of materials that may come through the line.

WORLDWIDE SALES AND SERVICE

Union Special Machine Company
One Union Special Plaza
Huntley, Illinois 60142

www.unionspecial.com
www.the-needles-eye.com
www.juki.com

**Single-needle
Bobbinless machine
for seaming trousers,
slacks, coats and
similar garments**

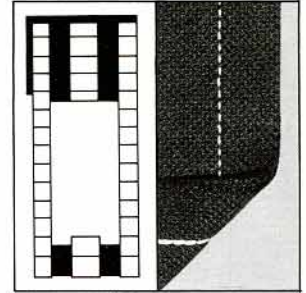

Style 56300G



This advanced machine offers manufacturers the ultimate in speed and performance for single-needle "Bobbinless" seaming. Style 56300G is engineered using all of today's knowledge of design and modern materials. Electronically balanced and SEW-TESTED to the highest standards in the history of sewing machine manufacturing to give you a high production unit that will sew today's newest fabrics at highest speeds.

**ADVANCED single-needle
Bobbinless machine offers
high speed and top production
when seaming trousers, slacks,
coats and similar garments**

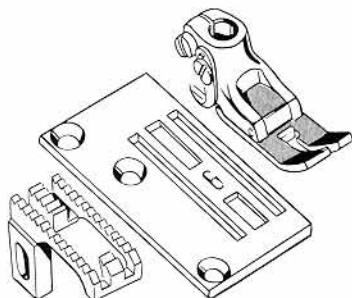

STYLE 56300 G

For seaming trousers, coats and similar operations on medium to medium heavy-weight material.

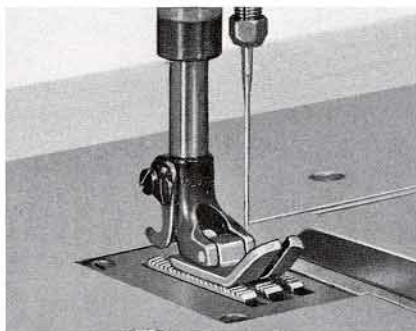

Close-up of Style 56300 G showing plain presser foot for the standard single-needle seamer.

Features Designed to Benefit Your Production and Quality

- NEW, HIGHER SPEEDS
- LESS PRESSER FOOT PRESSURE
- INDEXED THREAD RATIO CONTROL
- NEW LOOPER THREAD TENSION MOUNTING
- AUTOMATIC LUBRICATION
- PRECISION MANUFACTURE

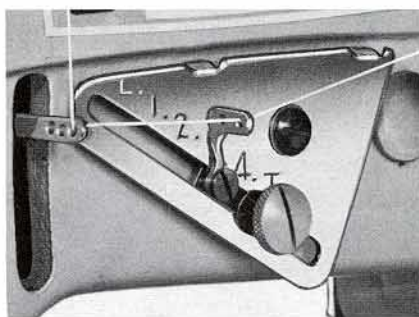

The thumbscrew adjustable needle thread frame eyelet assembly is capable of reducing seam pucker using a loose stitch as required with one fast, simple adjustment. This new indexed thread ratio control is calibrated clearly so that, with the machine set for one type of material, the operator, by simply moving the eyelet to a new position, can obtain the stitch best suited to other types of materials that may come through the line.

SPECIFICATIONS



Seam Specification 401 SSa-1

- Seam Specification 401 SSa-1
 Stitch Range 10 to 14 S.P.I.
 Standard Setting 14 S.P.I.
 Sewing Capacity $\frac{3}{8}$ " (9.52mm)
 Maximum Speed 6500 S.P.M.

WORLDWIDE SALES AND SERVICE

Union Special Machine Company
 One Union Special Plaza
 Huntley, Illinois 60142

www.unionspecial.com
www.the-needles-eye.com
www.juki.com

**High production
single-needle, plain-feed
bobbinless machine
for operations requiring
BACK TACKING**

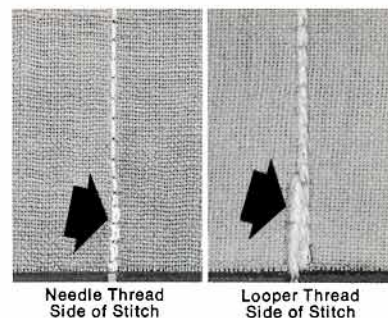

Back tacking with a bobbinless machine offers production increases when compared to any lockstitch machine. Work handling is the same. To back tack, the presser foot is raised by a conventional knee press. Style 56300V is a direct lockstitch machine replacement; no additional operator training is necessary. A unique "four motion" looper thread retainer mechanism prevents skipped stitches when sewing small radius turns. The 56300V is ideal for seaming and/or hemming dresses, skirts, towels, sheets, curtains and similar items.

High speed, high production single-needle, plain-feed bobbinless machines are superior to lockstitch machines for operations requiring back tacking



FEATURES

- NO BOBBIN—NO HOOK
- PERFECT STITCH FORMATION AND EASY THREAD HANDLING
- "FOUR MOTION" LOOPER THREAD RETAINER PREVENTS SKIPPED STITCHES ON TURNS
- AUTOMATIC LUBRICATION
- QUICK STARTING AND STOPPING
- HIGHEST QUALITY WORK
- LONGER LIFE AND SMOOTHER OPERATION

Tests show that *Style 56300V* is capable of increasing production substantially and reducing costs because it uses no bobbin and has a higher operating speed. Also, when the proper thread combination is used, the stitching on the underside has the fine appearance to meet quality standards for most finishing operations which previously were done on bobbin-type machines. Union Special produces both lockstitch and double locked stitch machines and, consequently, we recommend the type machine which we feel will do the best job.

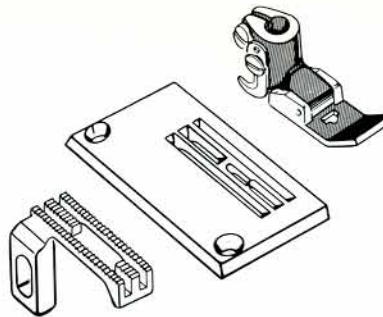

STYLE 56300V
Medium throw machine with back tacking mechanism, for seaming and/or hemming dresses, skirts, shirts, towels, sheets, curtains and for similar operations on light to medium weight woven materials where back tacking is required. Feed-teeth cut 22 T.P.I. Seam margin to right of needle 7/32".

Seam Specification

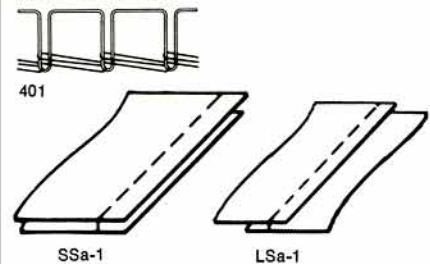

SPECIFICATIONS

STYLE 56300V
Seam Specification 401 SSa-1
Stitch Range 9 to 16 S.P.I.
Standard Setting 12 S.P.I.
Needle Type 130 GHS-036 (ball eye)
Needle Thread 70-3 soft
Looper Thread 100-2 soft
Speed, sew-tested up to ... 6500 S.P.M.
Sewing Capacity 3/8 inch (4.76 mm)
Installation Fully Submerged

WORLDWIDE SALES AND SERVICE

Union Special Machine Company
One Union Special Plaza
Huntley, Illinois 60142

www.unionspecial.com
www.the-needles-eye.com
www.juki.com



High speed two- and three-needle flatbed machines for double and triple stitch lap seaming operations on a wide variety of medium to heavy weight materials.

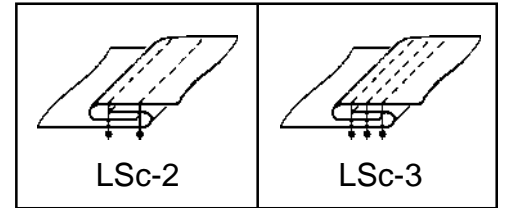

Combining speed and rugged reliability, these two- and three-needle flatbed machines are specifically designed for lap seaming operations on overalls, coveralls, jeans, service pants, industrial uniforms, work jackets, sport jackets, windbreakers and similar garments of medium to heavy weight materials.

STYLE 56500R
 STYLE 56900P
 STYLE 56900R



Two- and three-needle machines for true double lap seaming operations on overalls, jeans, jackets and similar garments of medium to heavy weight materials.

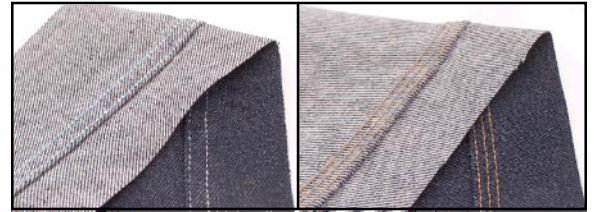

- FEATURES: • SPEEDS up to 6000SPM • HIGHEST QUALITY SEAMING • QUICK START and STOP
 • PERFECT STITCH FORMATION and EASY THREAD HANDLING
 • AUTOMATIC LUBRICATION for LONG LIFE and SMOOTH OPERATION

MACHINE	FEATURES	APPLICATION	SEAM and STITCH TYPE	GAUGE	FABRIC WEIGHT and TYPE	STITCH LENGTH	MAX. SPEED*
56500R -16 -18	Two-needle, four-thread , plain feed, high throw machine. With double lap seam folder, tractor type presser foot, and flat sewing parts designed for chaining between pieces.	For attaching risers to jeans, bibs to overalls, and piecing sleeves on denim jackets.	401LSc-2	1/4" or 9/32" 6.4 or 7.2mm	Medium to heavy weight materials.	7 to 14 SPI 2.3 to 3.6mm	6000 SPM
56900P -8 -9	Three-needle, six-thread , plain feed, high throw machine. With double lap seam folder, tractor type presser foot, and flat sewing parts designed for chaining between pieces.	For attaching risers to jeans, bibs to overalls, and piecing sleeves on denim jackets.	401LSc-3	1/8" or 9/64" 3.2 or 3.6mm	Medium to heavy weight materials.	7 to 12 SPI 2.1 to 3.6mm	6000 SPM
56900R -8 -9	Three-needle, six-thread , plain feed, high throw machine. With double lap seam folder, tractor type presser foot, and .070 stepped (1.75mm) sewing parts designed for chaining between pieces.	For seat seaming and similar operations on jeans, overalls and denim jackets.	401LSc-3	1/8" or 9/64" 3.2 or 3.6mm	Medium to heavy weight materials.	7 to 12 SPI 2.1 to 3.6mm	6000 SPM

* Depending on operation

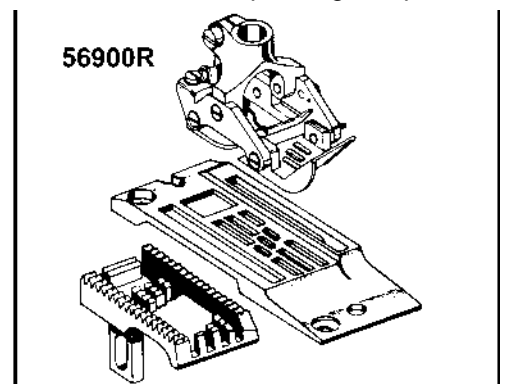
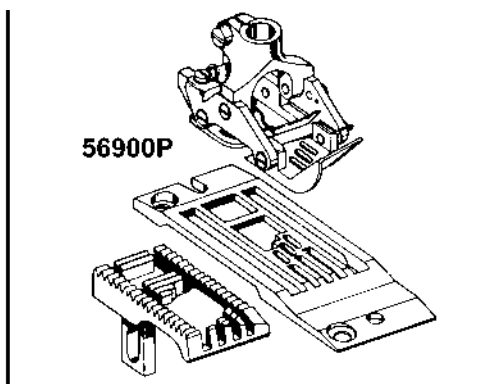
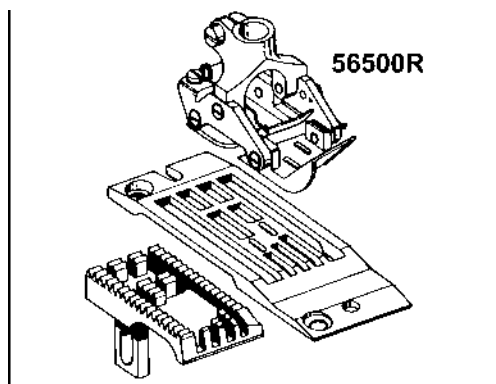

Union Special Corporation
 One Union Special Plaza
 Huntley, IL 60142
 www.unionspecial.com
 www.juki.com

Distributed by: